

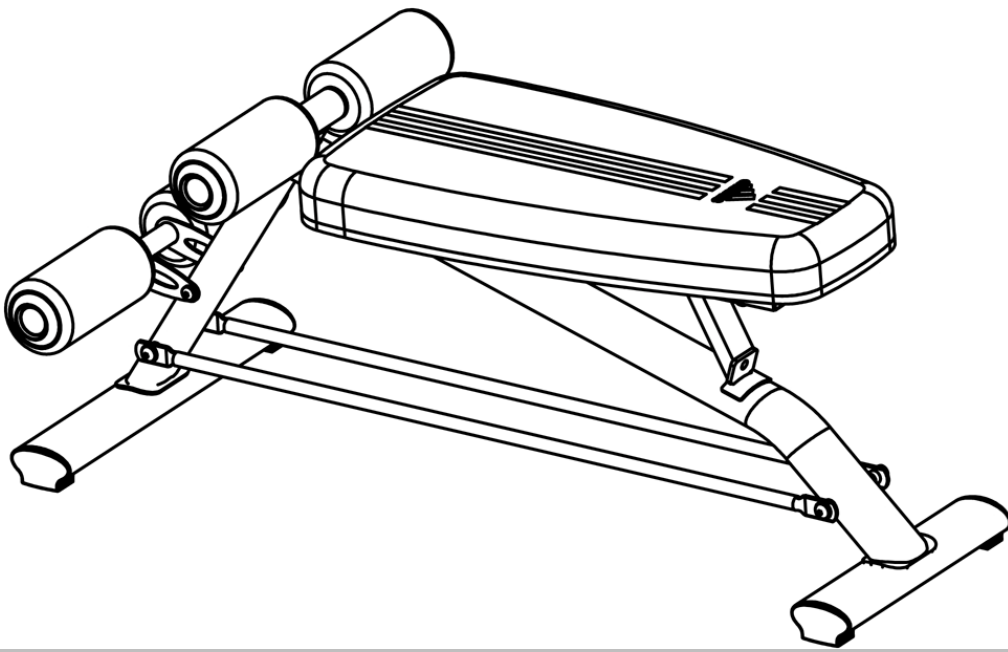

CRUNCH BOARD

ADI-415



IMPORTANT: Please read the Important Safety Notice and Assembly Information in the Owner's manual before assembling this product.

ATTENTION! Veuillez lire l'Avis de sécurité important et le Guide d'assemblage avant d'assembler cet appareil.

Assembly Manual Guide d'assemblage

111220

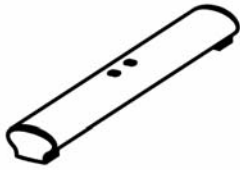

①×1



②×1

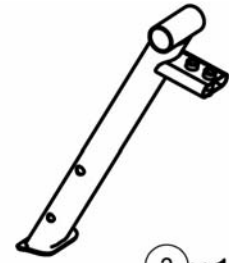

③×1

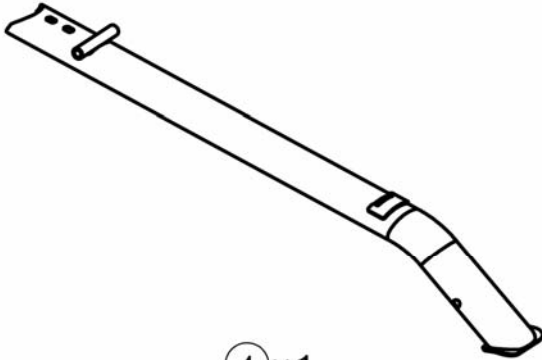

④×1



⑤×2



⑥×2



⑦×1

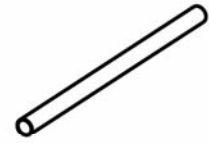

⑧×1



⑩×1



⑪×1



⑫×4



⑨×6



⑬×2



⑮×4



⑯×2



⑳×5



㉔×1

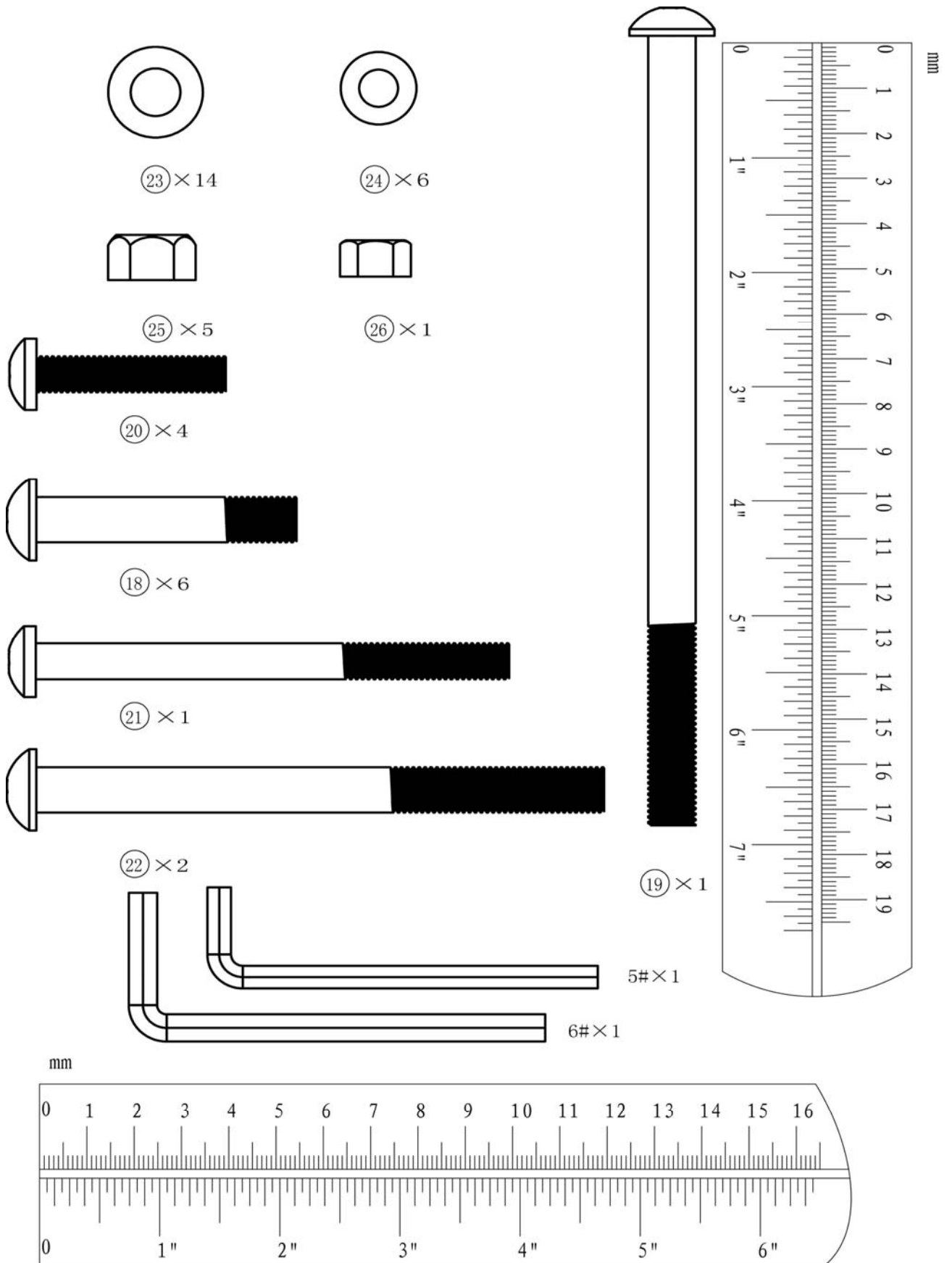

18  x 2 M10 x 2 1/8"

23  | x 4 Ø 3/4"

25   x 2 M10

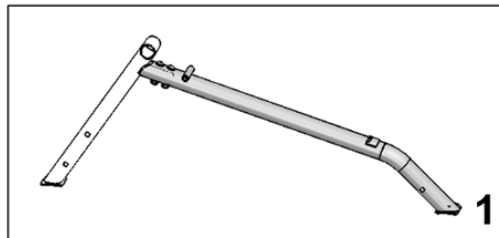
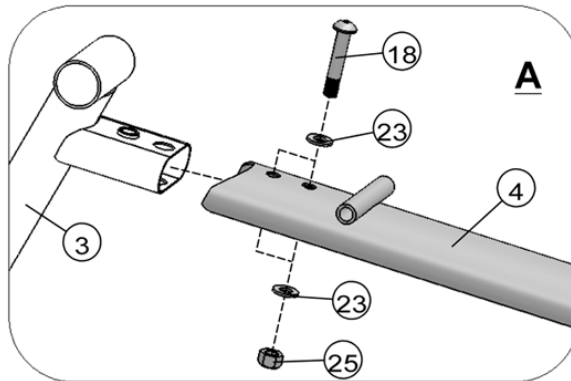
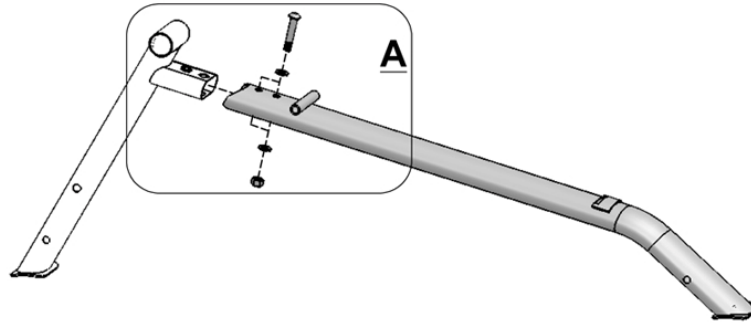
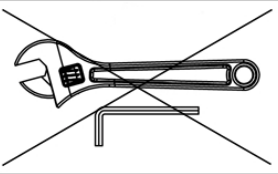



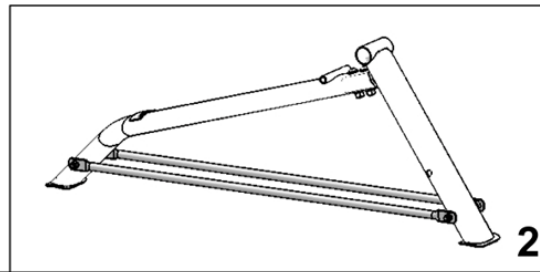
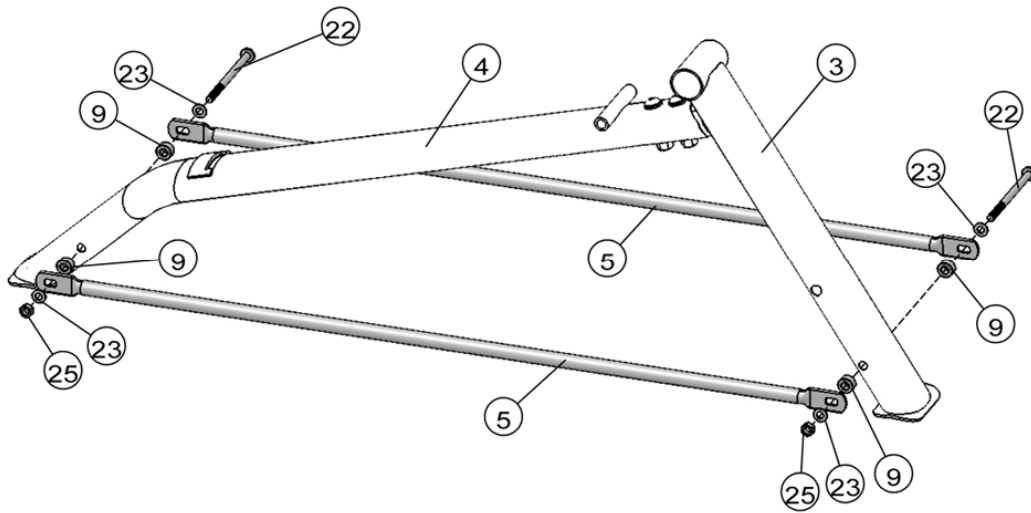

- 22  × 2 M10 × 4 3/4"
- 23  | × 4 Ø 3/4"
- 25  □ × 2 M10

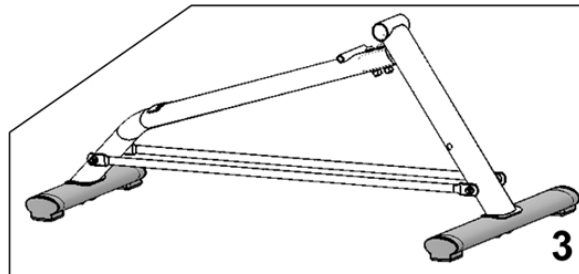
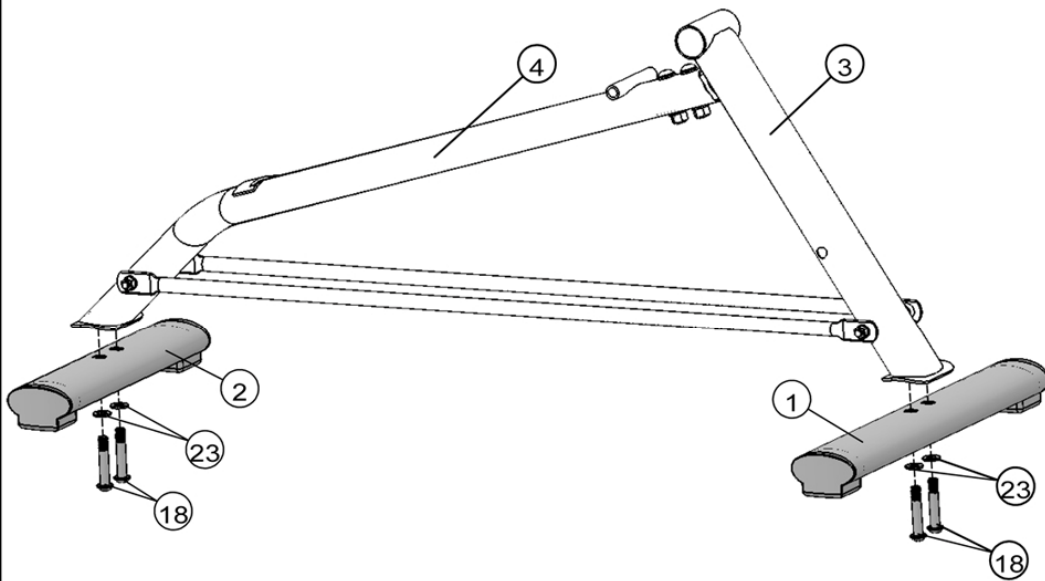
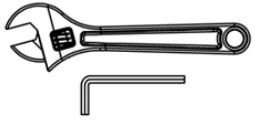

18  × 4 M10 × 2 1/8"



23  | × 4 Ø 3/4"

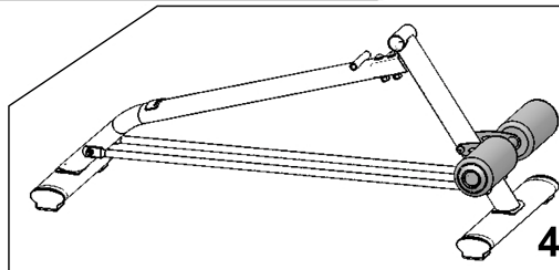
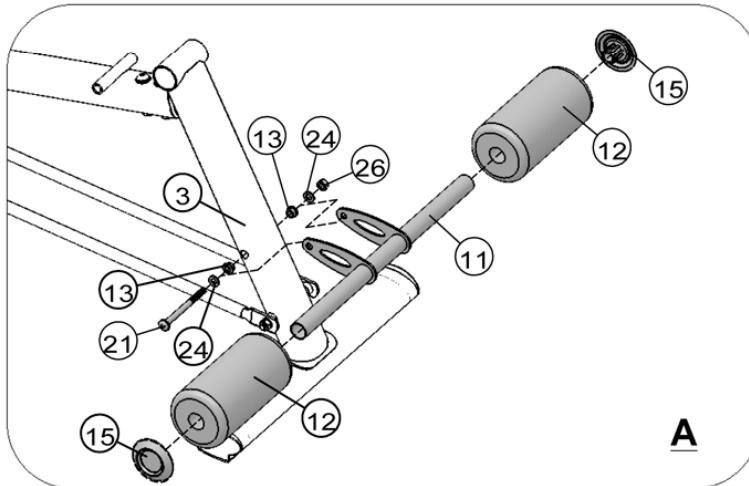
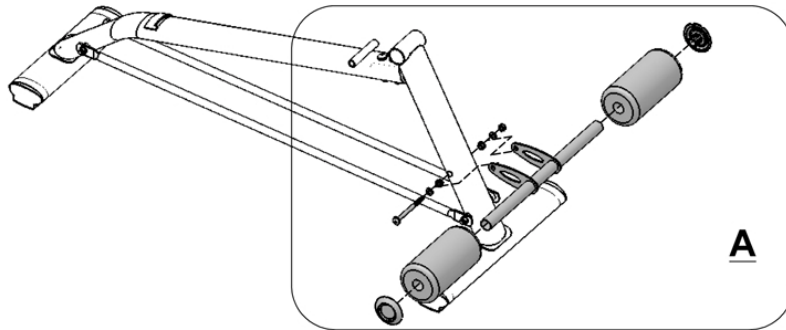

- ②①  × 1 M8 x 4"
- ②④  | × 2 Ø 5/8"
- ②⑥   × 1 M8

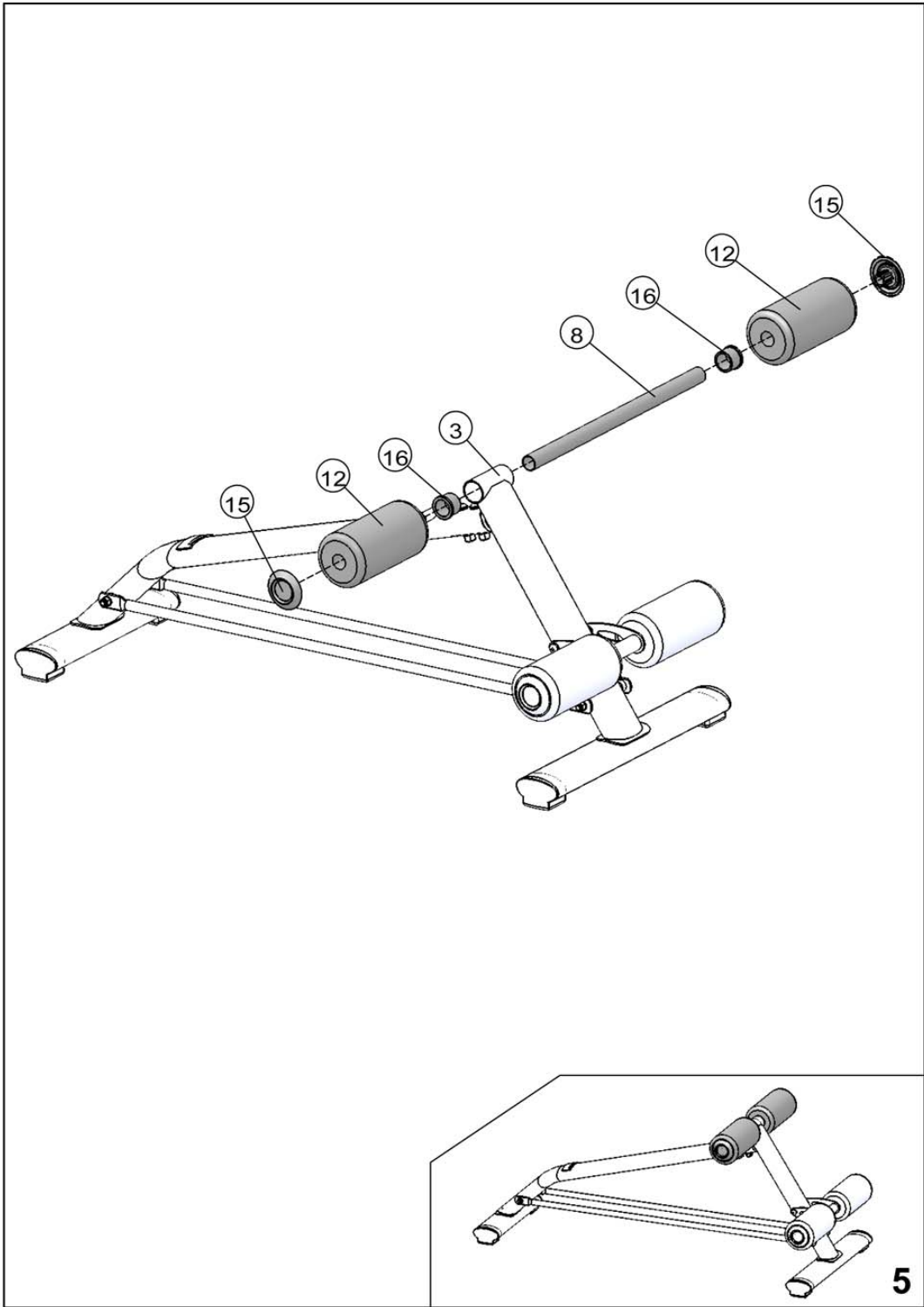



- ①⑨  × 1 M10×6 7/8"
- ②③  | × 2 Ø 3/4"
- ②⑤  B × 1 M10

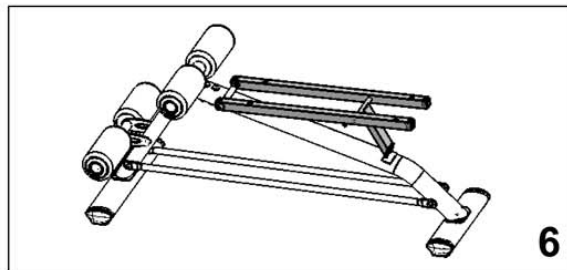
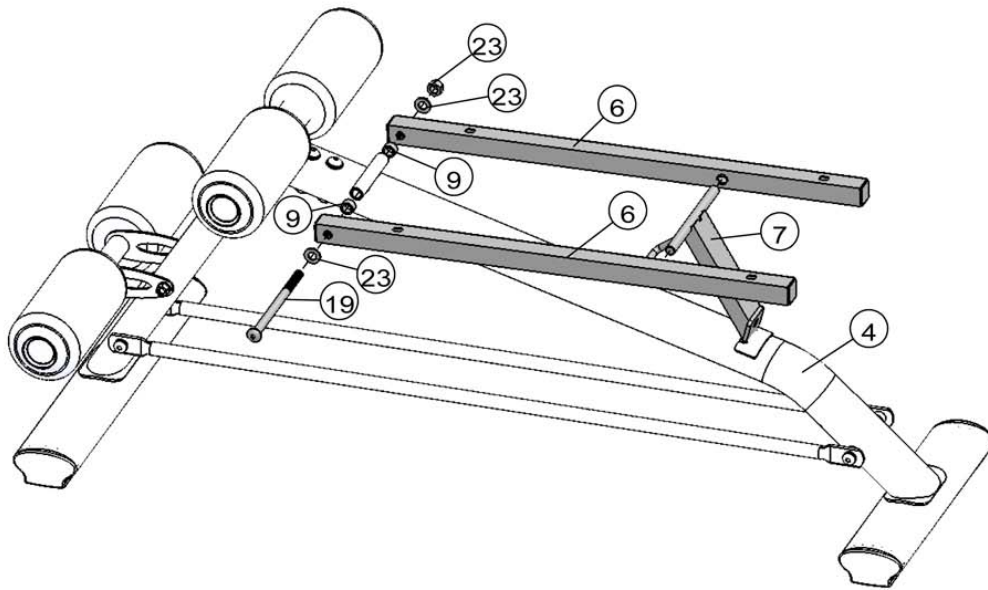
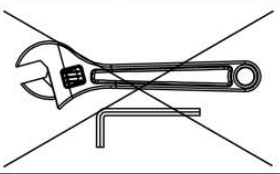

②① × 4 M8 x 1 5/8"

②④ × 4 Ø 5/8"

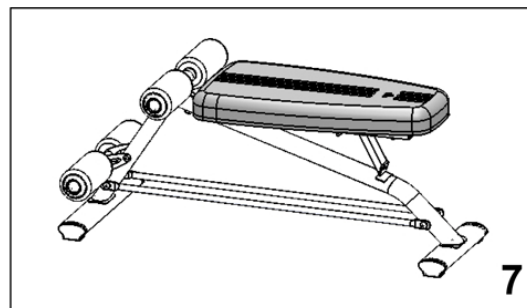
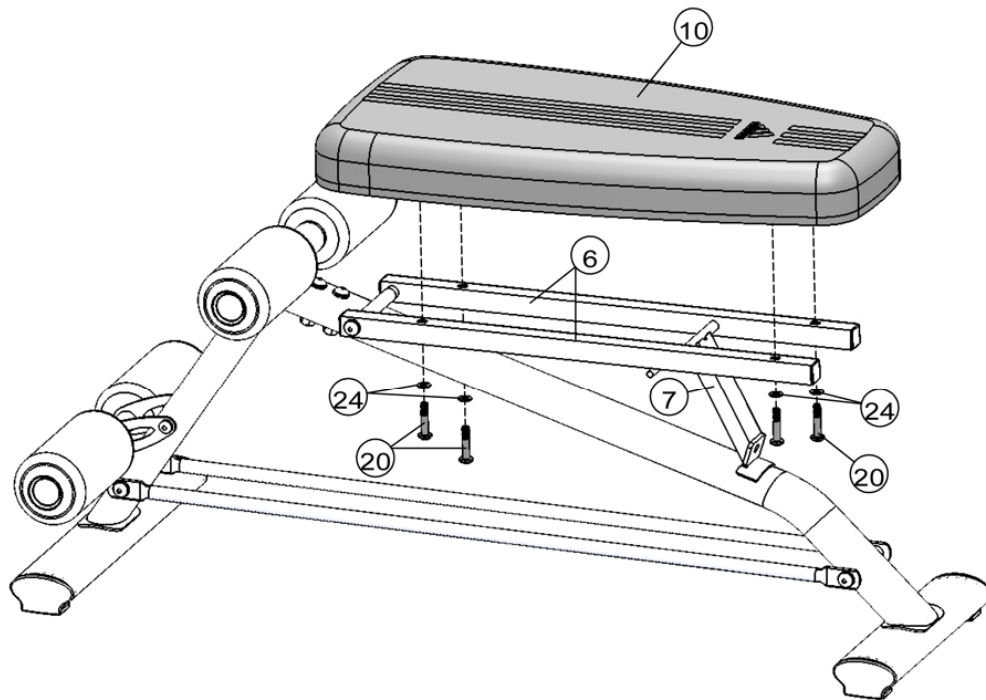

27 × 5 M10

28 × 1 M8

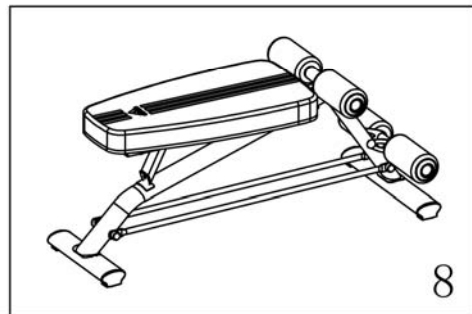
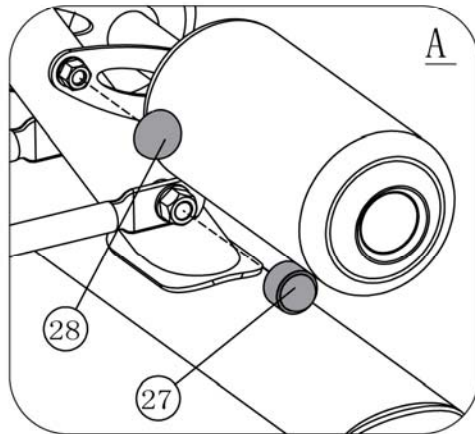
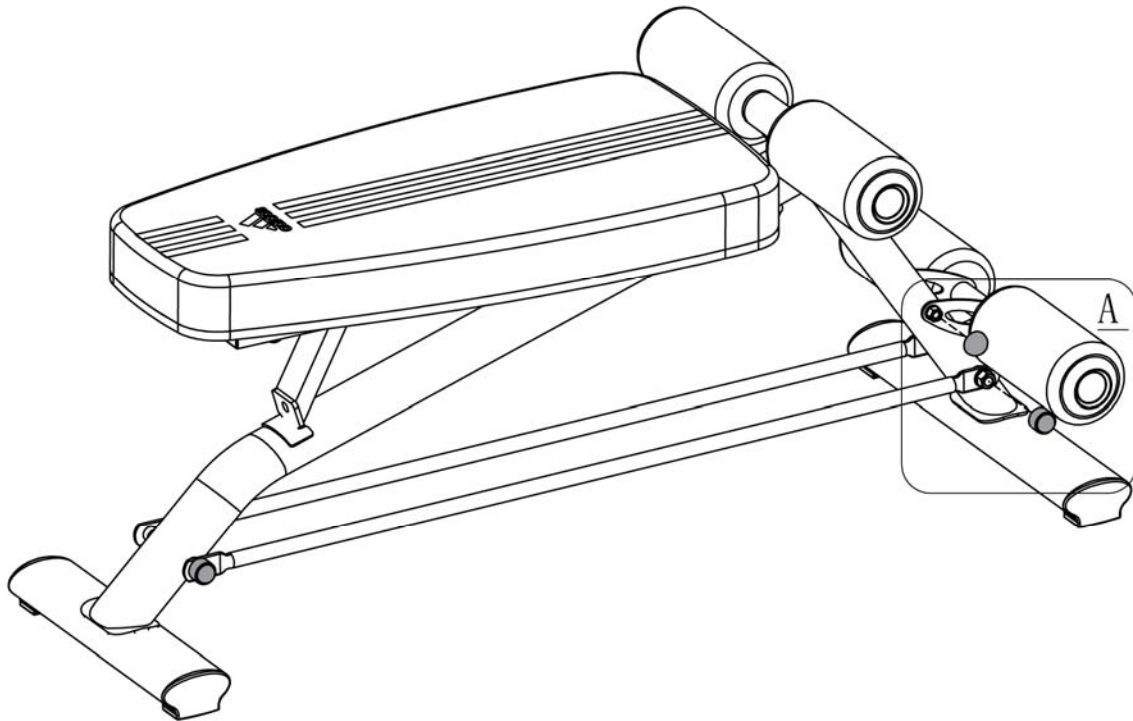

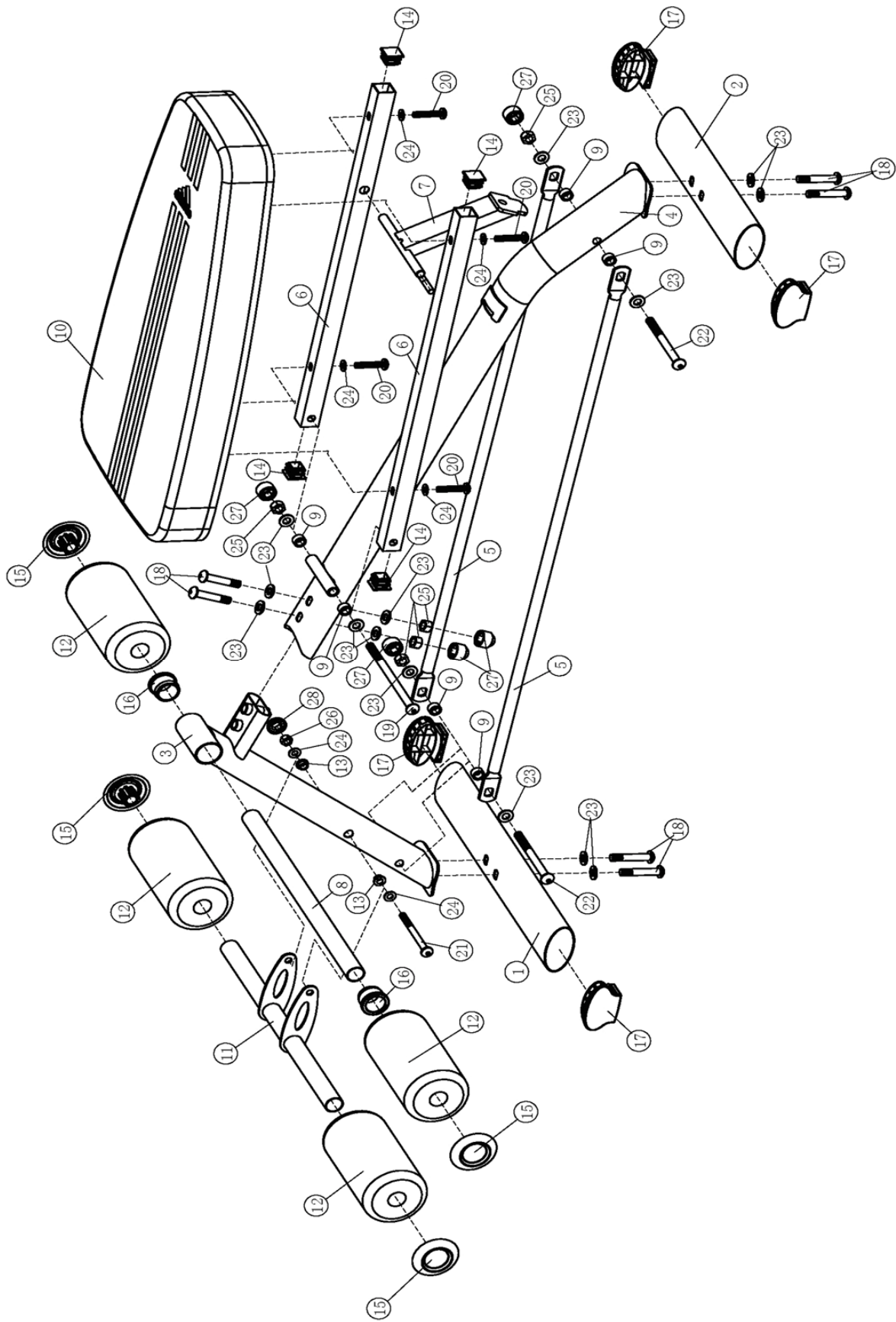

IMPEX[®] INC.

2801 S. Towne Ave, Pomona, CA 91766

Tel: (800) 999-8899 Fax: (626) 961-9966

www.impex-fitness.com

info@impex-fitness.com